

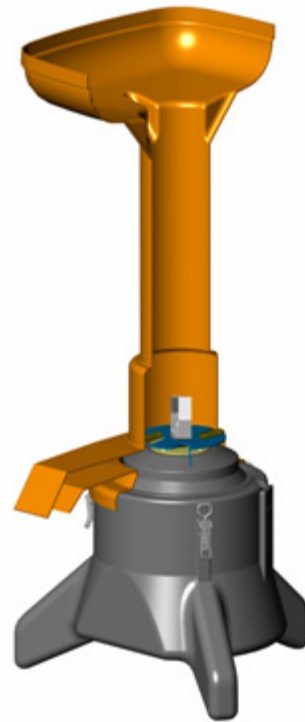

Translated from original

Operating Instructions for *Pome Fruit Grinder*

Item No.: 22200



1	GENERAL INFORMATION	3
2	SAFETY INSTRUCTIONS	3
3	OVERVIEW OF PARTS/SCOPE OF DELIVERY	5
4	TECHNICAL DATA	5
5	PRIOR TO FIRST USE	5
6	OPERATING THE DEVICE	6
7	CLEANING, MAINTENANCE, STORAGE	6
8	TROUBLESHOOTING.....	6
9	DISPOSAL.....	7
10	WARRANTIES.....	7

1 General information

Dear Customer,

You purchased a new product from Speidel. Thank you very much for your trust. When it comes to our products, quality and functionality are of our primary concern.

Intended use:

The pome fruit grinder is designed for the fine cutting of pomaceous fruit (e.g., apples, pears) so that a direct and optimal processing in a juicer (SPEIDEL Hydro Press) provides the best juice yield possible. The pome fruit grinder was delivered in ready-to-use condition and may only be used for crushing pome fruit. The grinder is not suitable for grinding of stone fruits such as cherries, etc. and shall never be used for shredding garden waste such as tree cutting, etc.

Operating instructions:



In order to ensure your new pome fruit grinder will work reliably and safely from the first time you use it and throughout its entire operating life, we have written these instructions. Please read them carefully before using the product for the first time. If you follow these tips and instructions carefully, the unit will work to your utmost satisfaction and will last you for a long time to come. Should you decide to pass this product on to a third party, please ensure to hand over the operating manual as well. To ensure, that you will enjoy your newly purchased grinder, please observe the following safety and operating instructions.



Declaration of Conformity

We, SPEIDEL Tank- und Behälterbau GmbH, herewith declare that the "Pome Fruit Grinder" referred to in these instructions to which this declaration relates, conforms with the requirements of the following guidelines:

EMV 2004/108/EG, Low Voltage 2006/95/EG, Machinery Directive 2006/42/EG

Manufacturer:

Speidel Tank- und Behälterbau GmbH
Krummenstrasse 2
D-72131 Ofterdingen
Germany

www.speidels-hausmosterei.de

www.speidel-behaelter.de

2 Safety instructions

General safety instructions:



- The equipment and the electrical connection including switch must be regularly inspected for signs of damage. If damage is detected, the unit must not be used.
- Install the power cord to prevent it from coming into contact with sharp objects (e.g. knives). Ensure to unwind the cable completely.
- If using an extension cord, the cable cross-section shall be at least 1.5 mm². Please ensure to completely unwind this extension cord as well. Do not use multi electrical outlets, as this unit is too powerful. **Risk of fire!**

- The press shall only be used as stated in the description of its intended purpose, and while technically safe and in flawless condition. Please ensure the units safe condition prior to any use.

Children and frail users:



- For the safety of your children, please remove or keep all packaging material (plastic bags, cardboard, Styrofoam, etc.) out of their reach. Prevent children from playing with plastic bags and/or foil. **Risk of suffocation!**
- The equipment is not intended for the use by persons (including children) with limited physical, sensory, or mental capabilities and shall not be operated by persons lacking experience and/or knowledge about the equipment, unless such person is supervised by another person who is familiar with relevant safety regulations. If children are present, they must be under constant supervision in order to ensure they remain out of harms way and do not play with the equipment.

Special safety instruction:

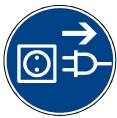

- Within the work area, the operator is responsible for the safety of third parties.
- The device may be activated only after the hopper is securely mounted onto the lower part.
- Safety devices shall neither be operated manually nor shall they be removed.
- The device must not be connected to the mains or operated without feed hopper.
- When transporting the pome fruit grinder, the unit must be shut off and removed from the power supply.
- Turn off the unit and disconnect supply lines before removing the hopper (e.g., for cleaning or maintenance purposes).
- Never spray water into the ventilation openings on the motor cover. **Danger of electrical shock!**
- Caution: If the hopper is removed, the blades may cause injuries, even if the motor is switched off. **Risk of injury!**
- Never reach inside the filler opening. Never place any objects other than those for which the grinder is intended for into the device. **Risk of injury!**
- Start the grinder before refilling and shut off only after complete processing of the filling material. Noncompliance may lead to problems during the restarting process.
- The pome fruit grinder must be placed securely on a flat, stable surface.
- Latches must be set so as to ensure a tight fit of the hopper.

3 Overview of parts/scope of delivery

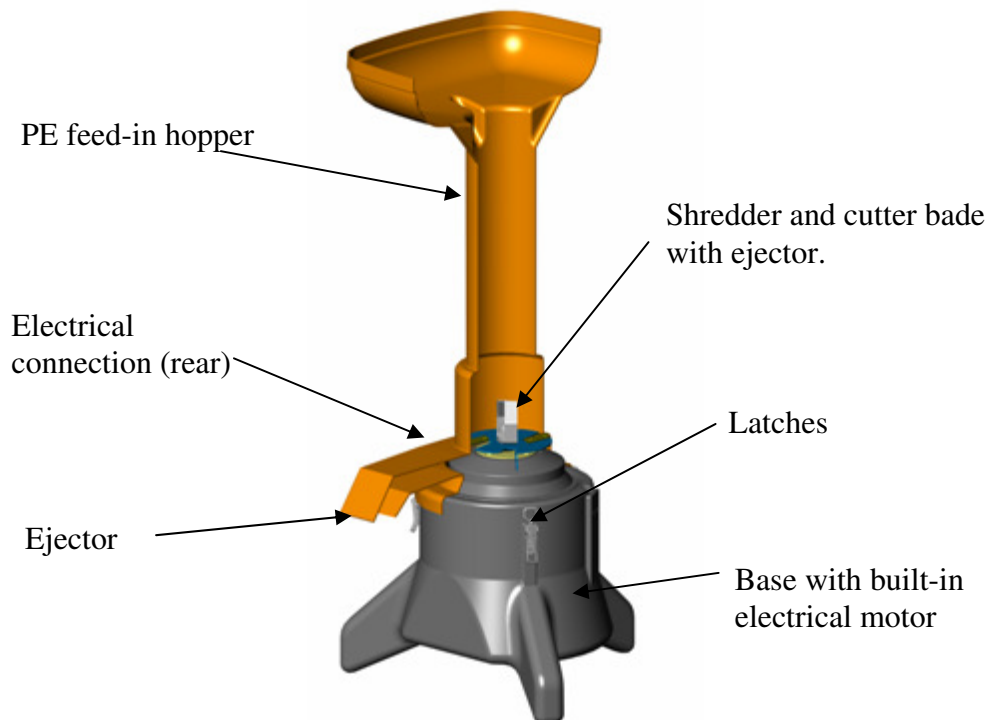

Note: The connecting cable is not included: We recommend a heavy rubber hose with a suitable cross section and connector.

4 Technical data

<u>Motor:</u>	230V~ / 50 Hz / 2.2 KW
<u>Electrical connection:</u>	230V / 50 Hz, shockproof electrical plug We recommend to install a residual current circuit breaker in the supply line
<u>Rotational speed:</u>	2,800 RPM
<u>Feed-in hopper:</u>	Solid, corrosion-resistant PE design with accidental activation prevention device
<u>Blades:</u>	Pre-shredder, cutting blade and rotary knives made of stainless steel
<u>Motor enclosure:</u>	Solid, corrosion-resistant PE design that encloses motor and wiring and prevents unauthorised access
<u>ON/OFF:</u>	Switch with zero voltage trigger and with accidental activation prevention device
<u>Fuse:</u>	Min. 16 A
<u>Dimensions:</u>	Ø660x1258 mm
<u>Weight:</u>	Approx. 25 kg
<u>Noise emission:</u>	75 dB(A) during idle operation

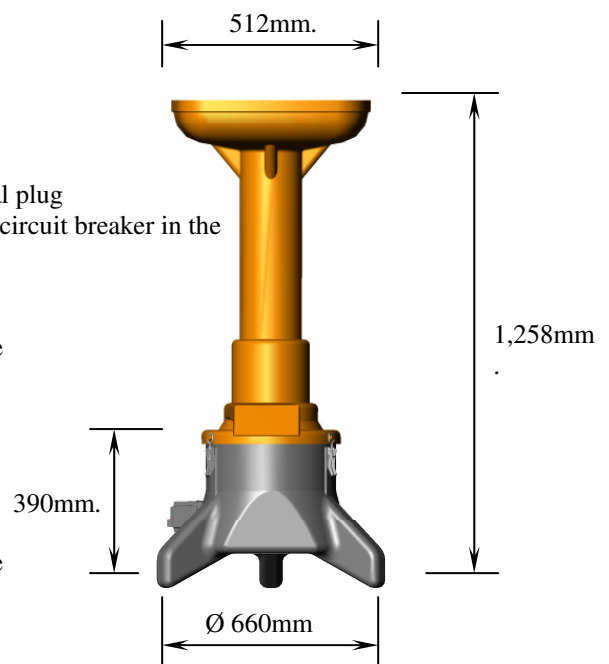

5 Prior to first use

Prior to its first use, the pome fruit grinder shall be thoroughly cleaned with water. Please provide a secure installation, placing the product on a flat and stable surface. Please ensure that the pome fruit grinder is in proper working condition. Please refer to the safety instructions in Chapter 2. Otherwise, the device is designed to start immediately.

6 Operating the device

The pome fruit grinder can be connected to any electrical AC line (230V/50 Hz). However, only one isolated ground receptacle is allowed, that is protected by a fuse having at least 16 A. We recommend installing a residual current circuit breaker in the line. If the device shuts off on its own during the operation, a malfunction such as fruit jammed in the cutting tool may be the cause. After the malfunction has been rectified, the device can be switched on again. Please refer to the respective safety instructions.

How to use the pome fruit grinder:

Simply connect the grinder to the power supply and switch it on (we recommend using a heavy rubber cable with a suitable cross section and connector to protect the electrical cord). Once the motor has reached its full speed, filling the grinder with a steady supply of fruit can be started. Please ensure that the fruit is fed into the hopper at an amount that can be easily processed by the grinder. This will allow for trouble-free operation and optimal output of approximately 1,000 kg/hour.

7 Cleaning, maintenance, storage

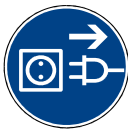

Always switch off the unit and unplug the power cord before cleaning the grinder. Please clean the grinder as soon as possible after each use in order to prevent the sweet juices or fruit residue to dry inside the press. Simply use water and a brush or cloth to clean the press. Never use a wire brush or other abrasive cleaning equipment. Do not use a powerful jet of water to spray underneath the cutting blade; it may damage the shaft's seal. Never spray water into electric components or in the engine compartment below. Never immerse the device in water for cleaning purposes. It may cause electrical shock or create a fire hazard.

As a maintenance measure only the shredder should be sharpened. The cutting blades can be turned/rotated to work again with a sharp knife edge. Always consider the safety instructions and remove the power plug from the mains during maintenance work.

To ensure the grinder's optimal service life, it should be stored in a dry place. Avoid contact between stainless steel parts (knives, shredders) and ferrous or corroded objects.

8 Troubleshooting

Never repair the machine yourself, always consult a qualified technician. In order to avoid any kind of danger, a faulty switch/plug/motor and other components may only be replaced or repaired by the manufacturer, our customer service department, or a qualified technician.

9 Disposal



Meaning of the "trash can" symbol on the pome fruit grinder: Protect our environment; electrical appliances do not belong into household waste. For the disposal of electrical equipment use only place provided for the collection and return of electrical devices which are no longer in use. Thus, you will help ensuring that the potential adverse impact on the environmental, caused by the incorrect disposal of waste, is avoided and human health is protected. This way, you contribute to the recovery, recycling and other forms of reuse of electrical and electronic equipment. Information on where the devices may be disposed of, can be obtained from your local or municipal authorities.

10 Warranties

Conditions:

- All legal warranty conditions apply. The warranty period for the use by non-commercial consumers is reduced to the regulations applicable to commercial customers, if such non-commercial consumer uses the product - even if only in part - for commercial purposes.
- Any warranty claim presented to us or one of our dealerships must be accompanied by a copy of the purchase order. In order to verify our warranty, please refer to the terms and conditions mentioned below.
- To ensure prompt processing of all warranty claims, discrepancies must be brought to our attention immediately after detection and submitted in writing, including a description of the defect and, if possible, photographs should be attached to the claim.
- Warranties do not apply to defects caused by noncompliance with the operating manual, improper handling, or normal wear and tear of the product. Warranty claims are also excluded for fragile parts or consumables, such as seals, gaskets, etc. Furthermore, warranty claims are excluded if repairs are performed by personnel other than authorized representatives or dealerships.

Processing:

In the unlikely event that your product requires repair during the warranty period, please contact us, submitting the respective warranty claim. The fastest and easiest option is returning the unit, or presenting a notice of defect to your authorized dealer/representative, or by contacting us directly:

E-mail: verkauf@speidel-behaelter.de

or fax to: 0049 – (0)7473 -9462-99

Please indicate your **complete address** and **contact information**. Furthermore, we require the **type designation** of the equipment under claim, a short **description of the malfunction** (if possible, please include **photographs**), **the date of purchase (copy of the invoice)** and the name of the **dealership** from where you have purchased the new product.

Once we have verified your notice of effect, we will contact you as soon as possible and explain further procedures. Please do not ship the unit as "carriage forward", "freight collect" or by similar shipping methods.



de	Sie vermissen eine Betriebsanleitung in einer verständlichen Sprache. Dann kontaktieren Sie bitte Ihren zuständigen Händler oder Importeur.
en	You miss an instruction manual in an accessible language. Then please contact your local dealer or distributor.
fr	Vous manquez un manuel d'instructions dans un langage accessible. Alors s'il vous plaît contactez votre revendeur ou distributeur local.
es	¿Echa de menos un manual de instrucciones en un lenguaje accesible. Entonces, por favor contacte a su vendedor o distribuidor local.
pt	Você perde um manual de instruções em linguagem acessível. Então, por favor contacte o seu revendedor ou distribuidor local.
pl	Tręsknisz instrukcja w przystępnym językiem. Następnie skontaktuj się z lokalnym sprzedawcą lub dystrybutorem.
no	Du savner en bruksanvisning på et lett tilgjengelig språk. Deretter kan du kontakte din lokale forhandler eller distributør.
fi	Menetät ohjekirjanen ymmärrettävällä kielellä. Sitten ota yhteyttä paikalliseen jälleenmyyjään tai maahantuojaan.
sv	Du missar en bruksanvisning på ett lättillgängligt språk. Vänligen kontakta din lokala återförsäljare eller distributör.
da	Du går glip af en brugsvejledning på et tilgængeligt sprog. Så kontakt din lokale forhandler eller distributør.
it	Ti manca un manuale di istruzioni in un linguaggio accessibile. Quindi contattare il rivenditore o distributore locale.
el	Χάνετε από εγχειρίδιο χρήσης σε προσιτή γλώσσα. Στη συνέχεια, επικοινωνήστε με τον τοπικό αντιπρόσωπο ή διανομέα.
hu	Hiányzik egy használati utasítás hozzáférhető nyelven. Ezután vegye fel a kapcsolatot a helyi forgalmazóval vagy a forgalmazóval.
nl	Je mist een handleiding in een toegankelijke taal. Neem dan contact op met uw lokale dealer of distributeur.
ro	E dor de tine un manual de instrucțiuni într-un limbaj accesibil. Apoi, vă rugăm să contactați distribuitorul local sau distribuitor.
ru	Вы не пропустите инструкцию на доступном языке. Тогда, пожалуйста, свяжитесь с вашим местным дилером или дистрибутором.
sk	Vám chýba návod na použitie v zrozumiteľným jazykom. Potom sa obráťte sa na miestneho predajcu alebo distribútora.
sl	Pogrešaj navodila v razumljivem jeziku. Potem se obrnite na lokalnega prodajalca ali distributerja.
bg	Можете да пропуснете инструкциите за употреба на достъпен език. Тогава, моля свържете се с местния дилър или дистрибутор.
sr	Мисс Иоу упутства на приступачан језику. Затим контактирајте локалног дистрибутера или дистрибутера.
hr	Vi propustiti pouku priručnik na pristupačan jeziku. Zatim obratite se svojem lokalnom zastupniku ili distributeru.
cs	Vám chybí návod k použití v srozumitelným jazykem. Pak se obraťte se na místního prodejce nebo distributora.
tr	Eğer erişilebilir bir dilde bir kullanım kılavuzu özledim. Daha sonra yerel satıcımıza veya distribütör başvurun.
zh	你错过易懂的语言中的一个指导手册。那么请联系您当地的经销商或分销商。
ja	あなたがアクセス可能な言語での取扱説明書を欠場。その後、お近くの販売店または特約店までご連絡ください。
ko	당신은 접근 언어로 사용 설명서를보고 싶어요. 그런 다음 해당 지역의 대리점 또는 대리점에 문의하시기 바랍니다.
th	คุณพลาดคู่มือการเรียนการสอนในภาษาที่สามารถเข้าถึง จากนั้นกรุณาติดต่อตัวแทนจำหน่ายหรือตัวแทนจำหน่ายใกล้บ้านของคุณ
vi	Bạn bỏ lỡ một sách hướng dẫn bằng ngôn ngữ dễ tiếp cận. Sau đó xin vui lòng liên hệ đại lý địa phương của bạn hoặc nhà phân phối.